



Mechanical Features

Passive Cool

DMT 01D

E-Bike Battery Pack

Gaurav Gidwani, Patapee Lohprasert, Po-chun Liu, Siqin Lin, Zirui Shao



Electrical Features

Specifications	Battery Pack
Battery	Samsung 30Q
Max Power (UK EAPC law)	250 W
Capacity	12000 mAh
Min Energy Density	196.6 Wh / l
Nominal Voltage	25.2 V
Charging time	7 hours
Battery Life	70 minutes
Battery Lifespan	300 cycles

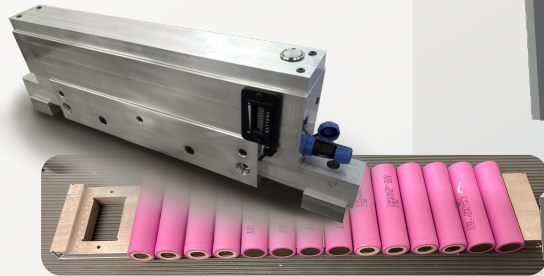
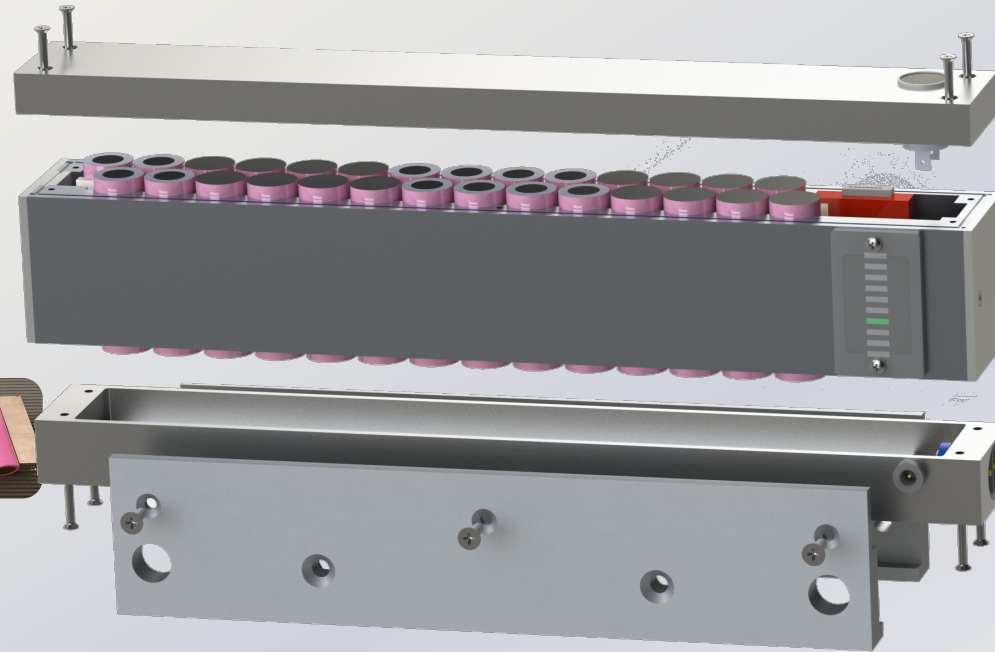
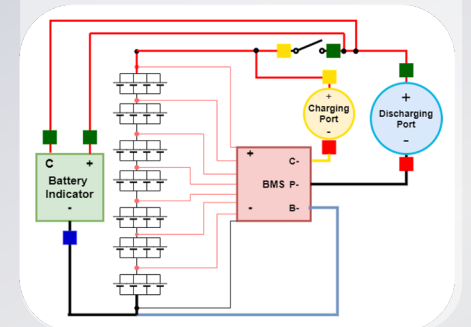

Designed for IP64

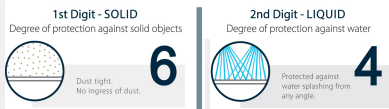

Budgeting

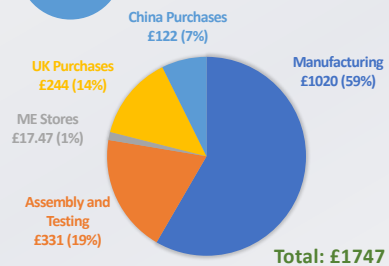

Testing



Ingress Test



Drop Test



Electrical Test



Results



Water leaked in



Survived up to 21G



Good thermal management

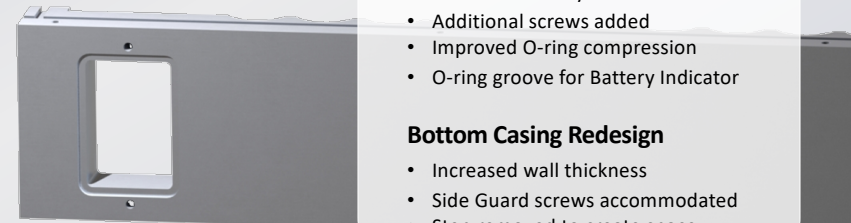
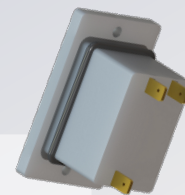

Improvements

Battery Holder Redesign

- Increases Battery Holders thickness
- Additional screws added
- Improved O-ring compression
- O-ring groove for Battery Indicator

Bottom Casing Redesign

- Increased wall thickness
- Side Guard screws accommodated
- Step removed to create space